



SERVICE BULLETIN

Periodic inspection of the float buoyancy for ROTAX® Engine Type 912 and 914 (Series)

ATA System: 73-00-00 Fuel system

MANDATORY

Symbols used:

Please, pay attention to the following symbols throughout this document emphasizing particular information.

General note



Identifies an instruction which, if not followed, may cause serious injury or even fatal injury.



Identifies an instruction which, if not followed, may cause minor or moderate injury.

NOTICE

Denotes an instruction which if not followed, may severely damage the engine or could lead to suspension of warranty.

ENVIRONMENTAL NOTE

Environmental notes give you tips on environmentally conscious behaviour.

NOTE: Information useful for better handling.

| A revision bar outside of the page margin indicates a change to text or graphic.

To obtain satisfactory results, procedures specified in this publication must be accomplished with accepted methods and prevailing government regulations.

BRP-Powertrain GmbH & Co KG. cannot be responsible for the quality of work performed in accomplishing the requirements of this publication.

SERVICE BULLETIN

1) Planning information

1.1) Applicability

All versions of the engine type:

Engine type	Serial number
912 A	from S/N 4 410 957
912 F	from S/N 4 413 008
912 S	from S/N 4 924 408
914 F	from S/N 4 421 136

Also affected are all floaters part no. 861184 which have been installed as spare part or during engine repair/general overhaul since 1. July 2012.

NOTE: The affected floaters were delivered with the engines listed above.
The part number and serial numbers of the carburetors:

Carburetors 912 A/F:

1/3 part no. 892500 - from S/N 116434;

2/4 part no. 892505 - from S/N 115846;

Carburetors 912 S:

1/3 part no. 892530 - from S/N 121087;

2/4 part no. 892535 - from S/N 120980;

Carburetors 914 F:

1/4 part no. 892520 - from S/N 116207;

2/4 part no. 892525 - from S/N 120228;

The carburetor and/or the float may have been removed from the first delivery engine and used on another one. Therefore the serial number of the carburetor is also important as the engine serial number.

For relevant information, see the maintenance records and/or the logbook.

1.2) Concurrent ASB/SB/SI and SL

Further to this Service Bulletin the following addition Service Instruction must be observed and complied with:

- Service Instruction-SI-912-021/SI-914-023, „Inspection of carburetors“, current Issue.

1.3) Reason

Due to a deviation in the manufacturing process some floaters could absorb more fuel and so have more weight. This leads to a loss of float buoyancy and wrong regulation of the fuel in the float chamber. Possible effects may be a rough engine running, especially at low speeds, engine stoppage and/or fuel leakage in the area of the carburetor.

d05799.fm

SERVICE BULLETIN

1.4) Subject

Periodic inspection of the float buoyancy of ROTAX® engine type 912 and 914 (Series).

1.5) Compliance

- Before the first installation in the aircraft and/or the initial start-up.
- Carry out this inspection of float buoyancy of the engines listed in section 1.1., according to the instructions in section 3 at the next BRP maintenance event or within the next 25 hours of operation, but latest after 60 days (from the date of the initial issue of this Service Bulletin).
- Carry out this inspection of float buoyancy of the engines listed in section 1.1., according to the instructions in section 3 periodically after each 25 hours of operation, but latest after 60 days.
- At rough engine running, especially at low engine speeds (crankshaft speed to 4000 rpm), fuel odor or fuel leakage carry out this inspection before the next flight. The cause (may also be independent of the floater) has to be fixed before the next flight.

NOTE: The inspection must be continued even after a replacement of the float, until new and improved floater are available. Only from this point the periodic inspection can be omitted. Corresponding information on this will be announced.



WARNING

Non-compliance with these instructions could result in engine damages, personal injuries or even fatal injury.

1.6) Approval

The technical content of this document is approved under the authority of DOA ref. EASA.21J.048.

1.7) Labor time

Estimated labor time:

- engine installed in the aircraft: labor time will depend on installation and therefore no estimate is available from the engine manufacturer

1.8) Mass data

change of weight - - none.

moment of inertia- - - unaffected.

1.9) Electrical load data

no change

1.10) Software accomplishment summary

no change

d05799.fm

SERVICE BULLETIN

1.11) References

In addition to this technical information refer to current issue of

- Maintenance Manual (MM) Heavy
- Maintenance Manual (MM) Line

NOTE: The status of Manuals can be determined by checking the table of amendments of the Manual. The 1st column of this table is the revision status. Compare this number to that listed on the ROTAX[®] Web-Site: www.FLYROTAX.com. Updates and current revisions can be downloaded for free.

1.12) Other Publications affected

none

1.13) Interchangeability of parts

- All parts are interchangeable.
- All affected parts cannot further be used and have to be returned F.O.B to a ROTAX[®] Authorized Distributors or their Service Center.

2) Material Information

2.1) Material- cost and availability

Price, availability and any possible support will be provided on request by ROTAX[®] Authorized Distributors or their Service Center.

2.2) Company support information

- The parts for the inspection of float buoyancy and for the replacement of any defective float are provided free of charge.
- Replace parts must be returned F.O.B to ROTAX[®] Authorized Distributors or their Service Center.
- Shipping costs, downtime costs, loss of income, telephone costs etc. or costs of conversion to other engine versions or additional work, as for instance simultaneous engine overhauls are not covered in this scope and will not be borne or reimbursed by ROTAX[®].

SERVICE BULLETIN

2.3) Material requirement per engine

Parts requirement for checking of the float buoyancy and for restoring the initial configuration:

NOTE: Use only parts indicated in the following table.

Part no.	Qty /engine	Description	Application
581385	1	Syringe	Engine type 912/914 Series
960043	1	Oil line 150 mm	
950030	2	Dichtung	Choke
224045	1	Diffuser tube	

Parts requirement for replacement of the floats:

	Qty /engine	Description	Application
861184	as required	Float (pair)	Engine type 912/914 Series
830728	2	Gasket	Float chamber 912/914 Series
631771	2	O-ring 15.6x1.78	Attachment screw 914 Series

2.4) Material requirement per spare part

none

2.5) Rework of parts

none

2.6) Special tooling/lubricant-/adhesives-/sealing compound

none

SERVICE BULLETIN

3) Accomplishment/Instructions

NOTE: Before maintenance, review the entire documentation to make sure you have a complete understanding of the procedure and requirements.

Accomplishment

All measures must be implemented and confirmed by at least one of the following persons or organization:

- ROTAX® - Distributors or their Service Center
- Persons with approved qualifications to the corresponding engine type. Only certified technicians (iRMT-Level: Line Maintenance) are qualified to work on these engines.

NOTE: All work has to be performed in accordance with the relevant Maintenance Manual.

Safety notice

 **WARNING**

Proceed with this work only in a non-smoking area and not close to sparks or open flames. Switch off ignition and secure engine against unintentional operation. Secure aircraft against unauthorized operation. Disconnect negative terminal of aircraft battery.

 **WARNING**

Risk of scalds and burns! Allow engine to cool sufficiently and use appropriate safety gear while performing work.

NOTICE

Should removal of a locking device (e.g. lock tabs, self-locking fasteners, etc.) be required when undergoing disassembly/assembly, always replace with a new one.

3.1) General

Adhere the installation instructions according to the ROTAX® Installation Manual regarding the carburetor venting or purging and the drip tray.

NOTICE

Do not modify the floaters!

SERVICE BULLETIN

3.1.1) Preparation

NOTE: The float chamber provides a different fuel level, depending on the float buoyancy.

In the following inspection the float chamber will be filled up to the venting bore and the required volume determined. The volume given indicates the resulting fuel level and provides information on the float status or buoyancy.

See [Fig. 1](#).

Step	Procedure
1	Bring the float chamber to horizontal position (level the aircraft, if necessary).
2	Let the engine idle for approx. 1-2 minutes. NOTE: Switch OFF the electric fuel pump (at 912 Series).
3	Remove the return spring (1).
4	Remove 4 Philips head screws (2). Remove rotary valve housing (3) with the gasket.
5	Remove the air vent line (4). Installed steel line must not be removed.

Fig. 1

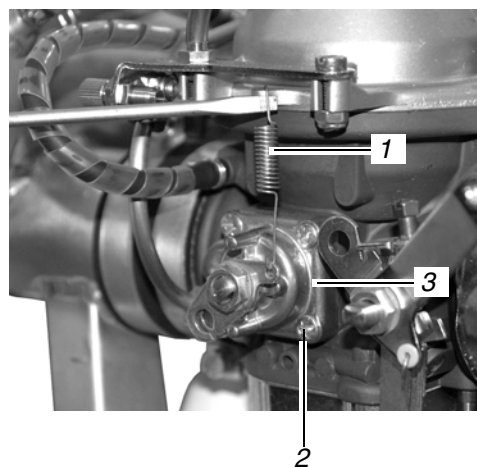

- 1 Return spring
- 2 Philips head screw M4x14
- 3 Rotary valve housing
- 4 Air vent line

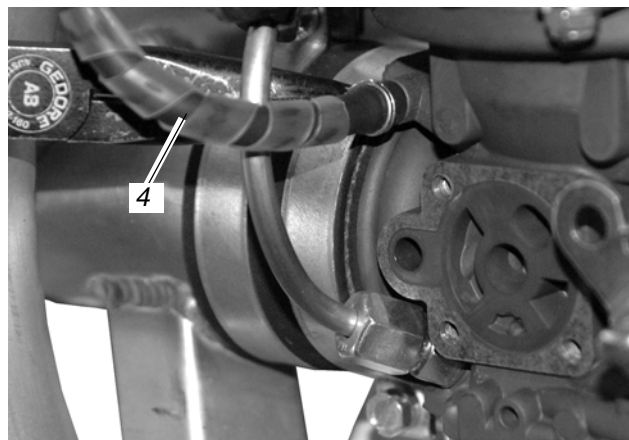

SERVICE BULLETIN

3.2) Inspection of float buoyancy

See Fig. 2

NOTICE

For inspection of the float buoyancy only use gasoline certificated by ROTAX (Mogas or AVGAS)! See latest SI-912-016/SI-914-019.

Step	Procedure
1	Fill the syringe (1) with 40-50 ml amount of fuel.
2	Connect syringe with the adapter (2) using a transparent fuel hose
3	Fuel hose and adapter must be free from air bubbles.
4	Insert the adapter (2) in the lower bore (3) of the rotary valve. Ensure a firm fit.

NOTE: During the following inspection of the volume, carefully fill the float chamber with a syringe until the fuel leaks from the venting nipple (4). This process should take about 5 seconds. Record capacity before the filling operation. The capacity can be determined by reading the scale of the syringe.

Fig. 2

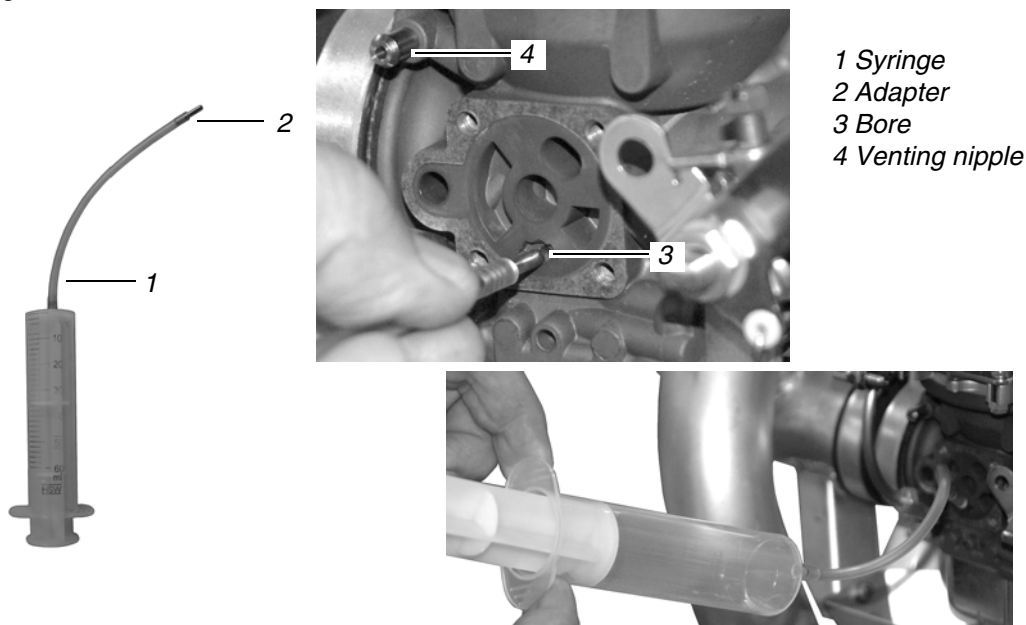

Step	Procedure
5	Fill the float chamber until the fuel leaks from the venting nipple.
6	Determine the volume.
7	Perform the same inspection on the second carburetor.
8	The results of the measurement must be documented in the maintenance records.

d05799.fm

SERVICE BULLETIN

3.2.1) Determination of the filling volume

Determine the filling volume by checking the scale of the syringe.

Filling volume in float chamber	Evaluation
23 ml - 40 ml	Floaters are OK, the float level is within the limit.
less than 23 ml	Significant deviation of the float levels. A detailed inspection of the floaters or their weight is necessary. See section. 3.5).
more than 40 ml	Significant deviation of the float levels. Repeat inspection to avoid incorrect measurements. See section 3.1.1). A detailed inspection of the carburetor and floaters or their weight is necessary. See section. 3.5). Check float needle valve for any leakage and setting of the float bracket.

3.3) Installation of the choke housing

See Fig. 3.

Step	Procedure
1	Install the venting line.
2	Install rotary valve with new gasket.
3	Secure first 2 threads of the Philips head screw 4x14 (1) with LOCTITE 243.
4	Install the return spring (2).

Fig. 3

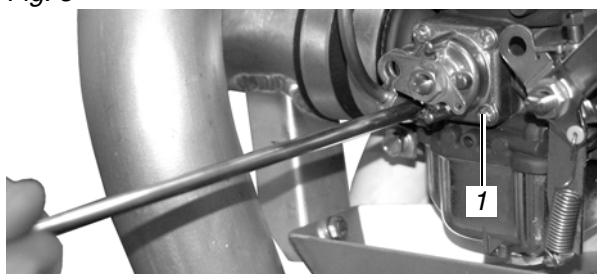

1 Philips head screw 4x14
 2 Return spring

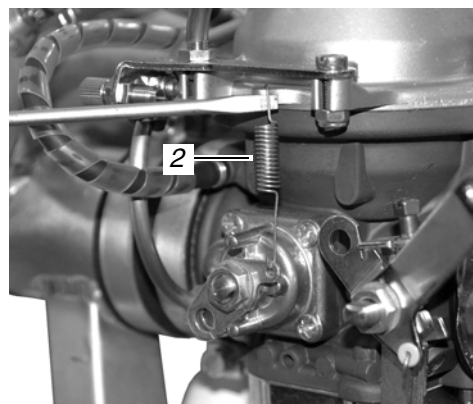

d05799.fm

SERVICE BULLETIN

3.4) Removal of float chamber

See Fig. 4.

NOTICE

If the inspection of float buoyancy section 3.5) shows a deviation, a weight control according to section 3.2) is necessary. For this purpose, as described below, the float chamber has to be dismantled.

Preparation for dismantling the float chamber according to the installation instructions of the aircraft manufacturer.

Step	Procedure
1	Remove drip tray (1).
2	Visual inspection of the carburetor and its mechanical actuation.
3	Remove spring clip (5) and for ROTAX 914 Series loosen cap screw (6) and remove with O-ring (7).
4	Remove float chamber (3), gasket (4) and the two floaters (2)

3.5) Check of weight of the floater

The weight inspection shows if the affected floaters have absorbed fuel. This is only meaningful if the floaters already have had contact with fuel.

NOTE: This check is not relevant for new spare parts, that were not in contact with fuel.

Step	Procedure
1	Let the floaters dry for 1-2 minutes. Only balance dry floaters.
2	Check the weight of all affected floaters using a calibrated balance (1). Measuring tolerance of the balance: max. 0.1 grams.
3	The results of the measurement must be documented in the maintenance records. The max. allowable weight (of both floaters) is 7 grams.

NOTICE

Renew all floaters which exceed the max. weight.

3.6) Installation of float chamber

10212

See Fig. 4.

Step	Procedure
1	Remove the gasket (4) from the float chamber and for ROTAX 914 Series remove the O-ring (7).
2	Install float chamber (3) with gasket (4) and the both floaters (2).
3	Close spring clip (5) or for ROTAX 914 Series install the attachment screw (6) including O-Ring (7). Tightening torque of attachment screw 5.5 Nm (48.7 in.lb).
4	Install drip tray (1).

Fig. 4

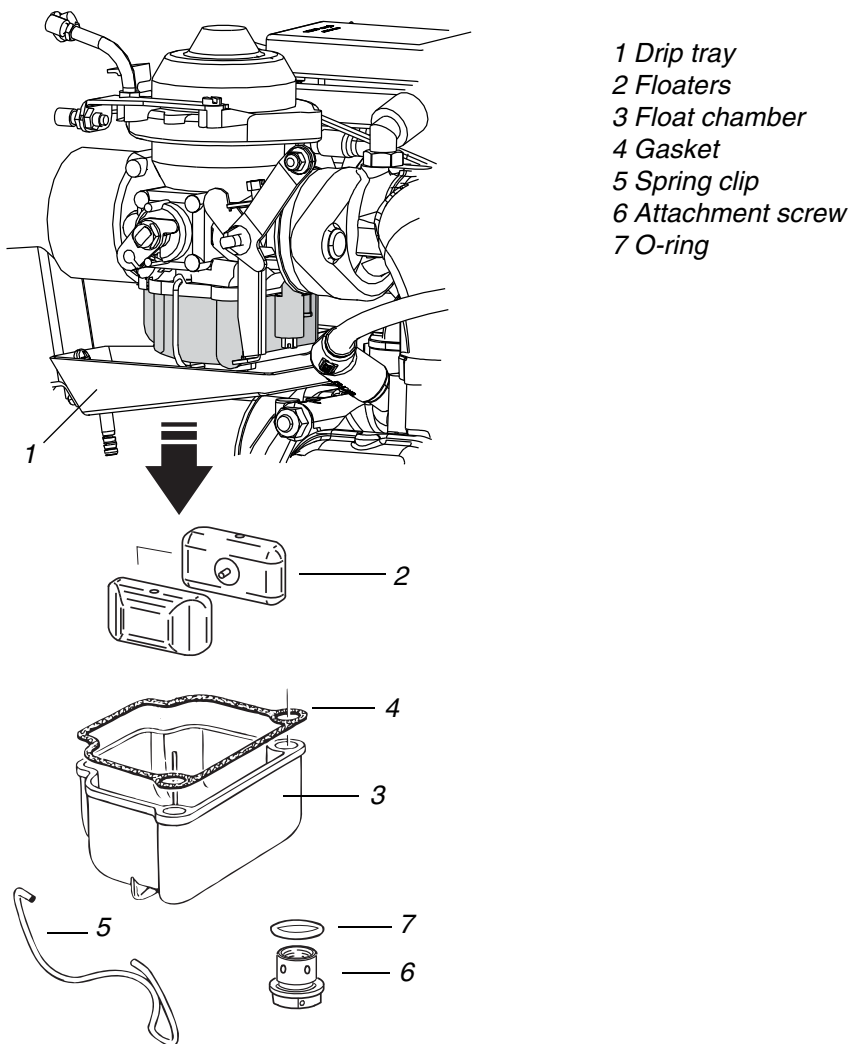

d05799.fm

SERVICE BULLETIN

3.7) Finishing work

- Restore aircraft to original operating configuration
- Connect negative terminal of aircraft battery.

3.8) Test run

Conduct test run. See also chapter 12-20-00 current issue Maintenance Manual Line of the engine type 912/914 Series.

3.9) Summary

These instructions (section 3) have to be conducted in accordance with the deadlines from section 1.5. The execution of the mandatory Service Bulletin must be confirmed in the logbook.

Approval of translation to best knowledge and judgement-in any case the original text in German language and the metric units (SI-system) are authoritative.

3.10) Enquiries

Enquiries regarding this Service Bulletin should be sent to the ROTAX® authorized distributor of your area. A list of all distributors is provided on www.FLYROTAX.com.

NOTE:

The illustrations in this document show a typical construction. They may not represent full detail or the exact shape of the actual parts but have the same or similar function.

Exploded views are **no technical drawings** and are for reference only. For specific detail, refer to the current documents of the respective engine type.